



180°  
Light bar  
Tilt

340°  
Light bar  
rotation

10.5m  
Expandable  
boom



## Mine Spec Series Features

- 12 months - 1500 hrs warranty
- 500 hr Service interval standard on all models
- Original equipment manufacturer
- Extra low voltage
- Total hydraulic controlled
- Auto start/stop
- Twin filtered engine oil standard
- 2 stage air filter system
- Low fuel level beacon - Automatic email @10%
- 3 stage Paint Protection Package as Standard inc Electronic E Coat

## Light Features

Military/aero grade titanium based coating

Military/aero grade soldering process

Copper PCB

Automatic thermal control

Failsafe light switch PCB for maximum protection

Smart brightness controlled without PWM

# MLT 2560-LED DUAL AXLE

## Model

Model	MLT2560-LED
Configuration	Dual Axle Trailer

## Dimensions

Width	2 000 mm
Length	5 200 mm
Height	2 450 mm
Net Weight	2 440 kg

## Engine and Generator

Fuel	Diesel
Engine	Kubota Z482-E
No Engine Cylinders	2
Engine Speed RPM	1 650
Engine Aspiration	Natural
Generator	Brushless
Generator Voltage	24 VDC
Tyre and Rim Size	235 R16
Stabiliser Supports	4 Hydraulic Legs
Tow Point	Ball or Ring Type

## Lights

Type of Lights	LED
No. of Lights	8
Light output (wattage)	2 560 w
Installed lamp Wattage	320 w
Installed total Lumens	532 480 lm
Lumens per Watt (max)	208 lm/w
Lamp life Hours	60 000

## Mast

Mast Height	10.5 m
Mast Rotation	340°
Wind Rating Speed	100 km/h

## Fuel

Fuel Capacity	240 L
Operating Hours at 100% Load	300 hours (0,8L/h)

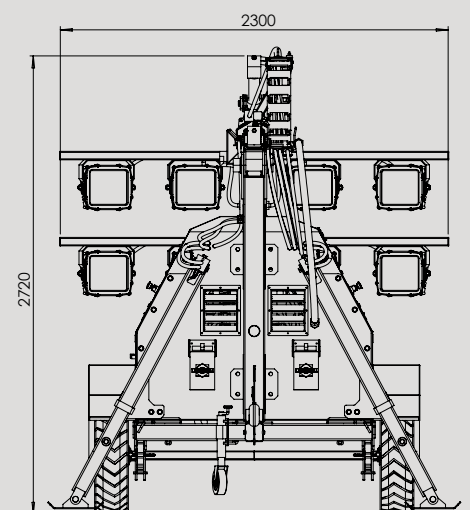
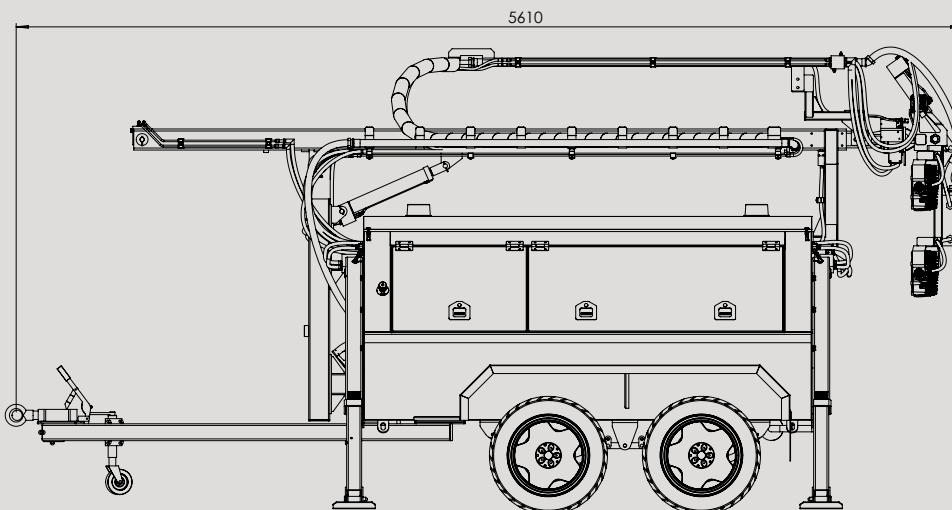

# MLT 2560-LED DUAL AXLE

## Axles, Brakes and Springs

---

Axle Rating	2.5 Tonne
Brakes	Mechanical (Option For Electric)
Park Brake	Mechanical
Hitch	Ball Or Ring Type
Tyre and Rim Size	235R16 All Terrain
Spring Rating	2.5 Tonne

## Fuel

---

Fuel Tank Capacity	Double Wall with 240l Capacity
Fill Point	2 Inch Cam Lock (Wiggins Optional)
Operating Hours at 100% load	300 Hours @ 0.8 L/H

## Electrical

---

Isolators	Lockable Starter and Battery
Jump Start Recepticle	Andersen Type
Beacons	Amber and Red (Low Fuel)
Controller	Smartgen ALC700

## Hydraulics

---

Manifolds	2 X 12 Volt 4 Station with Test Port
Motor	2.2KW 12 Volt Fan Cooled
Filter	10 Micron on Return Circuit
Pipes	CNC Stainless Bent Pipe
Hoses	MDG41 with Burst Sleeve
Safety valves	Double Pilot Check Valaves on All Cylinders

## 3 Stage Paint Process

---

Stage 1	Raw Steel Hydrostatically Dipped @ 180 Deg Celcius
Stage 2	Primed and Seam Sealed
Stage 3	2 Pak Polyurethane (White Std) Other Colours Available

## Other

---

Fire Extinguisher	1 x 4.5kg Dry Chemical Powder
Call Sign	2 X As Per Customer Request

